

CHAPTER 22

Electric Fields

BEIRUT SECTION

Mainly, every week one chapter will be introduced in the order shown in the following table (tentative schedule).

LECTURE	DATE	CHAPTERS
1,2	SEP 24, 26	Chapter 21: Electric Charge
3,4	OCT 1,3	Chapter 22: Electric Fields
5,6	OCT 8,10	Chapter 23: Gauss' Law
7,8	OCT 17,22,24	Chapter 24: Electric Potential
9,10	OCT 29, 31	Chapter 25: Capacitance
EXAM I (Chapter 21-25)		
11,12	NOV 5,7	Chapter 26: Current and Resistance
13,14	NOV 12,14	Chapter 27: Circuits
15,16	NOV 19,21	Chapter 28: Magnetic Fields
17,18	NOV 26,28	Chapter 29: Magnetic Fields Due to Current
19,20	DEC 3,5	Chapter 30: Induction and Inductance
EXAM II (Chapter 26-30)		
20,21	DEC10, 12	Chapter 31: Electromagnetic Oscillations and Alternating Current
22,23	DEC 17,19	Chapter 32: Maxwell's Equations
24,26	JAN 7, 9, 14,16,21	Chapter 33-34: Electromagnetic Waves - Images
FINAL EXAM (Chapter 21-34)		

BYBLOS SECTION

Mainly, every week one chapter will be introduced in the order shown in the following table (tentative schedule).

LECTURE	DATE	CHAPTERS
1,2,3	SEP 23,25,27	Chapter 21: Electric Charge
4,5,6	SEP 30, OCT 2,4	Chapter 22: Electric Fields
7,8,9	OCT 7,9,11	Chapter 23: Gauss' Law
10,11,12,13	OCT 16,18,21,23	Chapter 24: Electric Potential
14,15,16	OCT 25,28,30	Chapter 25: Capacitance
EXAM I (Chapter 21-25)		
17,18,19	NOV 1,6,8	Chapter 26: Current and Resistance
20,21	NOV 11,15	Chapter 27: Circuits
22,23	NOV 18,20	Chapter 28: Magnetic Fields
24,25,26	NOV 25,27,29	Chapter 29: Magnetic Fields Due to Current
27,28,29	DEC 2,4,6	Chapter 30: Induction and Inductance
EXAM II (Chapter 26-30)		
30,31,32	DEC 9,11,13	Chapter 31: Electromagnetic Oscillations and Alternating Current
33,34,35,36	DEC 16,18,20, 23	Chapter 32: Maxwell's Equations
37,38,39,40,41	JAN 8,10,15,17,20	Chapter 33-34: Electromagnetic Waves - Images
FINAL EXAM (Chapter 21-34)		

22-1

The Electric Field

Learning Objectives

- **22.01** Identify that at every point in the space surrounding a charged particle, the particle sets up an electric field \mathbf{E} , which is a vector quantity and thus has both magnitude and direction.
- **22.02** Identify how an electric field \mathbf{E} : can be used to explain how a charged particle can exert an electrostatic force \mathbf{F} on a second charged particle even though there is no contact between the particles.
- **22.03** Explain how a small positive test charge is used (in principle) to measure the electric field at any given point.
- **22.04** Explain electric field lines, including where they originate and terminate and what their spacing represents.

22-1 The Electric Field

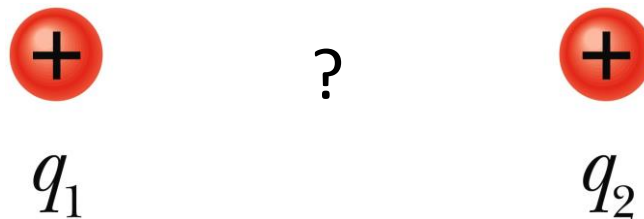

How does particle 1 “know” of the presence of particle 2?

That is, since the particles do not touch, how can particle 2 push on particle 1—how can there be such an action at a distance?

22-1 The Electric Field

Electric Field



q_1



q_2

Copyright © 2014 John Wiley & Sons, Inc. All rights reserved.

ANSWER

- Particle 2 sets up an electric field at all points in the surrounding space, even if the space is a vacuum.
- If we place particle 1 at any point in that space, particle 1 knows of the presence of particle 2 because it is affected by the electric field particle 2 has already set up at that point. Thus, particle 2 pushes on particle 1 not by touching it as you would push on a coffee mug by making contact. Instead, particle 2 pushes by means of the electric field it has set up.

22-1 The Electric Field

- The electric field is a vector field
- How to measure the electric field ?

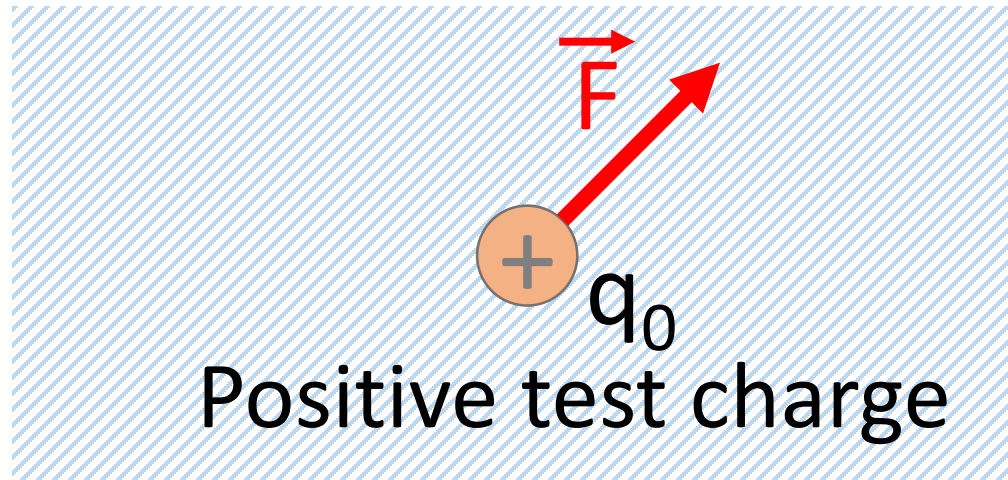

The electric field \vec{E} at any point is defined in terms of the electrostatic force \vec{F} that would be exerted on a positive test charge q_0 placed there:

$$\vec{E} = \frac{\vec{F}}{q_0}$$

The SI unit is (N/C)

22-1 The Electric Field

Electric Field Lines

- Electric field lines help us visualize the direction and magnitude of electric fields.
- The electric field vector at any point is tangent to the field line through that point.



Electric field lines extend away from positive charge (where they originate) and toward negative charge (where they terminate).

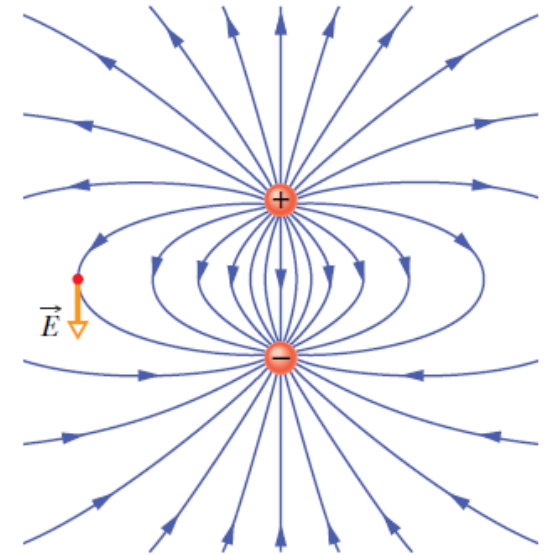
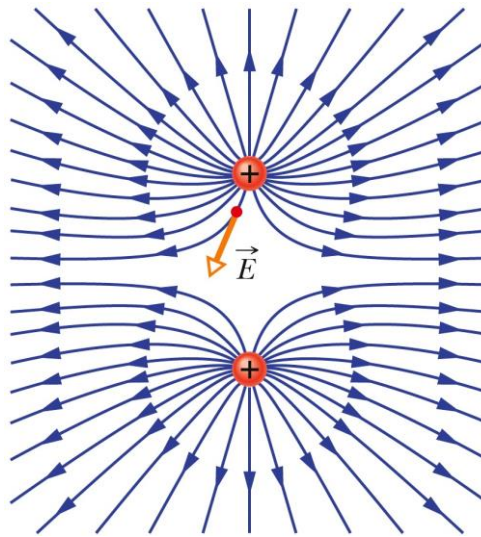
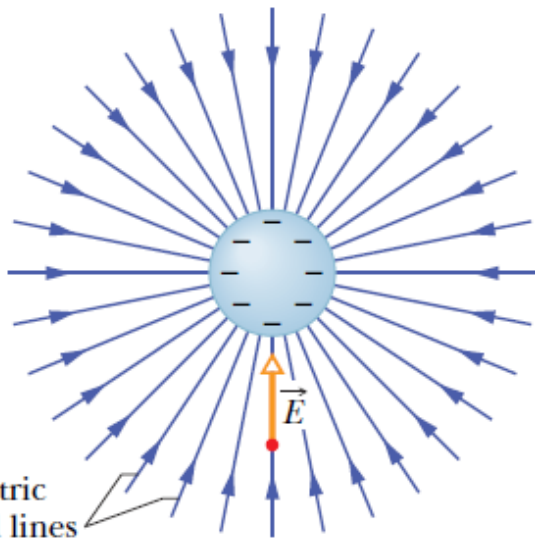

22-1 The Electric Field

Uniform Electric Field

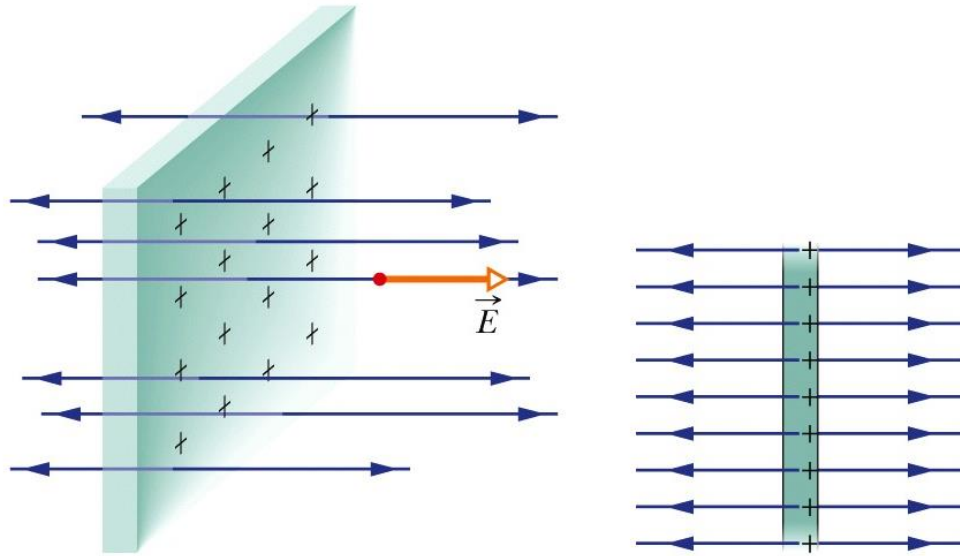

The electric field of a very large (infinite) non-conducting sheet with uniform positive charge is a uniform electric field (same direction, same magnitude at any point)

Our goal in this chapter is to define electric field and discuss how to calculate it for various arrangements:

1) Electric Field Due to a Charged Particle

Our goal in this chapter is to define electric field and discuss how to calculate it for various arrangements:

- 1) Electric Field Due to a Charged Particle**
- 2) Electric Field Due to a Dipole**

Our goal in this chapter is to define electric field and discuss how to calculate it for various arrangements:

- 1) Electric Field Due to a Charged Particle**
- 2) Electric Field Due to a Dipole**
- 3) The Electric Field Due to a Line of Charge**

Our goal in this chapter is to define electric field and discuss how to calculate it for various arrangements:

- 1) Electric Field Due to a Charged Particle**
- 2) Electric Field Due to a Dipole**
- 3) The Electric Field Due to a Line of Charge**
- 4) The Electric Field Due to a Charged Disk**

22-2

The Electric Field Due to a Charged Particle

22-2 The Electric Field Due to a Charged Particle

Learning Objectives

- **22.05** In a sketch, draw a charged particle, indicate its sign, pick a nearby point, and then draw the electric field vector \mathbf{E} : at that point, with its tail anchored on the point.
- **22.06** For a given point in the electric field of a charged particle, identify the direction of the field vector \mathbf{E} : when the particle is positively charged and when it is negatively charged.
- **22.07** For a given point in the electric field of a charged particle, apply the relationship between the field magnitude E , the charge magnitude $|q|$, and the distance r between the point and the particle.
- **22.08** Identify that the equation given here for the magnitude of an electric field applies only to a particle, not an extended object.
- **22.09** If more than one electric field is set up at a point, draw each electric field vector and then find the net electric field by adding the individual electric fields as vectors (not as scalars).

22-2 The Electric Field Due to a Charged Particle

The magnitude of the electric field E set up by a particle with charge q at distance r from the particle is

$$E = \frac{1}{4\pi\epsilon_0} \frac{|q|}{r^2}$$

The **electric field vectors** set up by a positively charged particle all point directly away from the particle. Those set up by a negatively charged particle all point directly toward the particle.

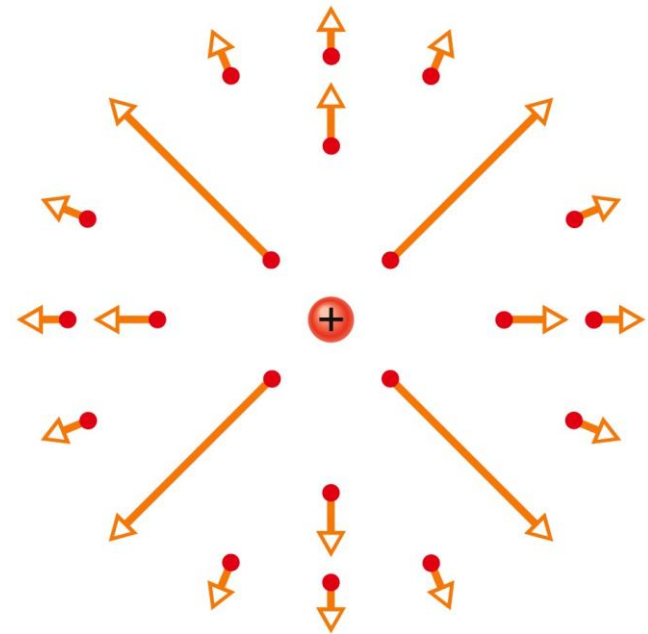

Copyright © 2014 John Wiley & Sons, Inc. All rights reserved.

The electric field vectors at various points around a positive point charge.

22-2 The Electric Field Due to a Charged Particle

If more than one charged particle sets up an electric field at a point, the net electric field is the vector **sum** of the individual electric fields—**electric fields obey the superposition principle**.

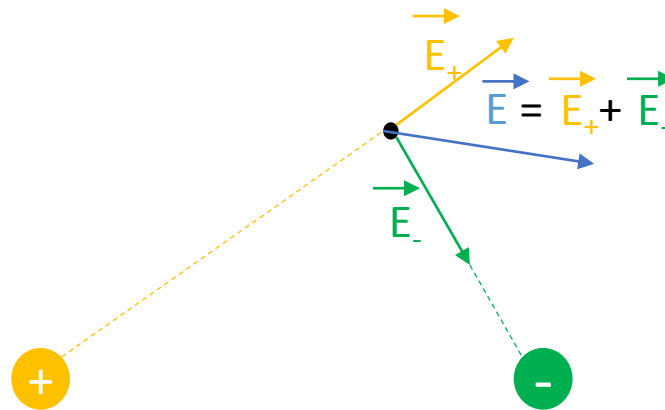

22-3

The Electric Field Due to a Dipole

22-3 The Electric Field Due to a Dipole

Learning Objectives

- **22.10** Draw an electric dipole, identifying the charges (sizes and signs), dipole axis, and direction of the electric dipole moment.
- **22.11** Identify the direction of the electric field at any given point along the dipole axis, including between the charges.
- **22.12** Outline how the equation for the electric field due to an electric dipole is derived from the equations for the electric field due to the individual charged particles that form the dipole.
- **2.13** For a single charged particle and an electric dipole, compare the rate at which the electric field magnitude decreases with increase in distance. That is, identify which drops off faster.

22-3 The Electric Field Due to a Dipole

Learning Objectives

- **22.14** For an electric dipole, apply the relationship between the magnitude p of the dipole moment, the separation d between the charges, and the magnitude q of either of the charges.
- **22.15** For any distant point along a dipole axis, apply the relationship between the electric field magnitude E , the distance z from the center of the dipole, and either the dipole moment magnitude p or the product of charge magnitude q and charge separation d .

22-3 The Electric Field Due to a Dipole

Electric Dipole

An electric dipole consists of two particles with **charges of equal magnitude q but opposite signs**, separated by a small distance d .

Electric dipole moment:

- **Magnitude: $p = qd$**
- **Direction: From the negative to the positive end of the dipole**

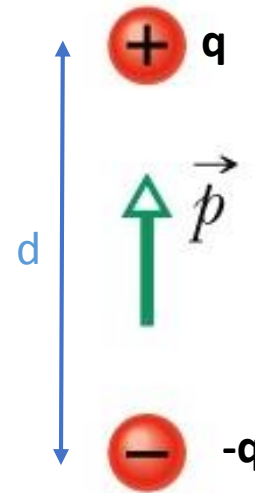

22-3 The Electric Field Due to a Dipole

Electric Dipole

The magnitude of the electric field set up by an electric dipole at a distant point on the dipole axis (which runs through both particles) can be written in terms of either the product qd or the magnitude p of the dipole moment:

$$E = \frac{1}{2\pi\epsilon_0} \frac{qd}{z^3} = \frac{1}{2\pi\epsilon_0} \frac{p}{z^3},$$

where z is the distance between the point and the center of the dipole.

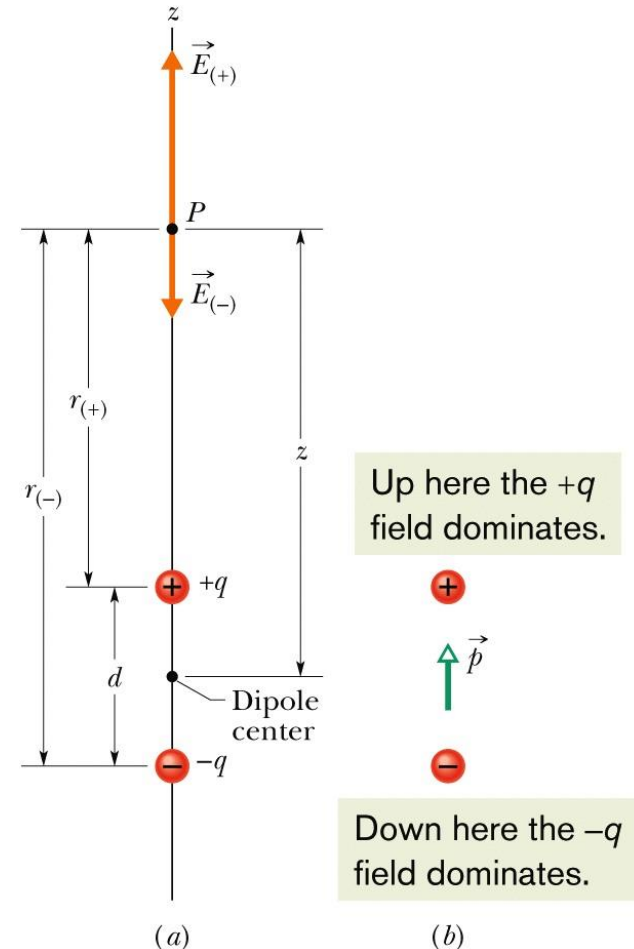

Copyright © 2014 John Wiley & Sons, Inc. All rights reserved.

22-4

The Electric Field Due to a Line of Charge

22-4 The Electric Field Due to a Line of Charge

Learning Objectives

- **22.16** For a uniform distribution of charge, find the linear charge density λ for charge along a line, the surface charge density σ for charge on a surface, and the volume charge density ρ for charge in a volume.
- **22.17** For charge that is distributed uniformly along a line, find the net electric field at a given point near the line by splitting the distribution up into charge elements dq and then summing (by integration) the electric field vectors $d\mathbf{E}$ set up at the point by each element.
- **22.18** Explain how symmetry can be used to simplify the calculation of the electric field at a point near a line of uniformly distributed charge.

22-4 The Electric Field Due to a Line of Charge





Key Concepts

- The equation for the electric field set up by a particle does not apply to an extended object with charge (said to have a **continuous charge distribution**).
- To find the electric field of an extended object at a point:
 - 1) We first consider the electric field set up by a charge element dq in the object, where the element is small enough for us to apply the equation for a particle.
 - 2) Then we sum, via integration, components of the electric fields $d\mathbf{E}$ from all the charge elements.
- Because the individual electric fields $d\mathbf{E}$ have different magnitudes and point in different directions, we first see if symmetry allows us to cancel out any of the components of the fields, to simplify the integration.

22-4 The Electric Field Due to a Line of Charge

Key Concepts

Some Measures of Electric Charge

Name	Symbol	SI Unit		
Charge	q	C		
Linear charge density	λ	C/m		$\lambda = \frac{dq}{ds}$
Surface charge density	σ	C/m ²		$\sigma = \frac{dq}{dA}$
Volume charge density	ρ	C/m ³		$\rho = \frac{dq}{dV}$

22-4 The Electric Field Due to a Line of Charge

Charged Ring

Canceling Components - Point P is on the axis: In the Figure (right), consider the charge element on the opposite side of the ring. It too contributes the field magnitude dE but the field vector leans at angle ϑ in the opposite direction from the vector from our first charge element, as indicated in the side view of Figure (bottom). Thus the two perpendicular components cancel. All around the ring, this cancelation occurs for every charge element and its symmetric partner on the opposite side of the ring. So we can neglect all the perpendicular components.

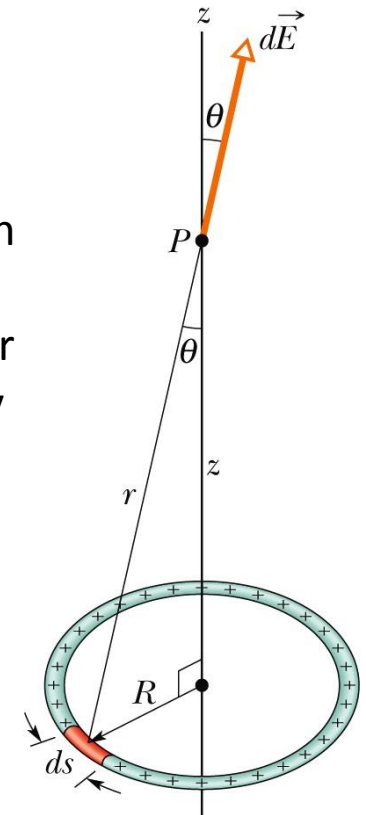

Copyright © 2014 John Wiley & Sons, Inc. All rights reserved.

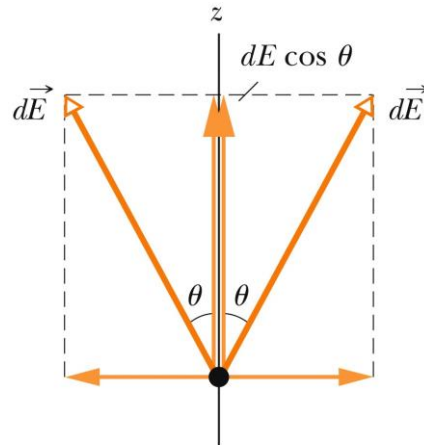

Copyright © 2014 John Wiley & Sons, Inc. All rights reserved.

The components perpendicular to the z axis cancel; the parallel components add.

A ring of uniform positive charge. A differential element of charge occupies a length ds (greatly exaggerated for clarity). This element sets up an electric field dE at point P .

22-4 The Electric Field Due to a Line of Charge

Charged Ring

Adding Components. From the figure (bottom), we see that the parallel components each have magnitude $dE \cos\theta$. We can replace $\cos\theta$ by using the right triangle in the Figure (right) to write

$$\cos \theta = \frac{z}{r} = \frac{z}{(z^2 + R^2)^{1/2}}$$

And, $dE \cos \theta = \frac{1}{4\pi\epsilon_0} \frac{z\lambda}{(z^2 + R^2)^{3/2}} ds$ gives us the parallel field component from each charge element

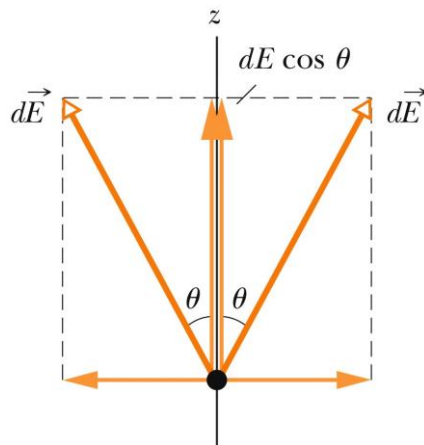

The components perpendicular to the z axis cancel; the parallel components add.

Copyright © 2014 John Wiley & Sons, Inc. All rights reserved.

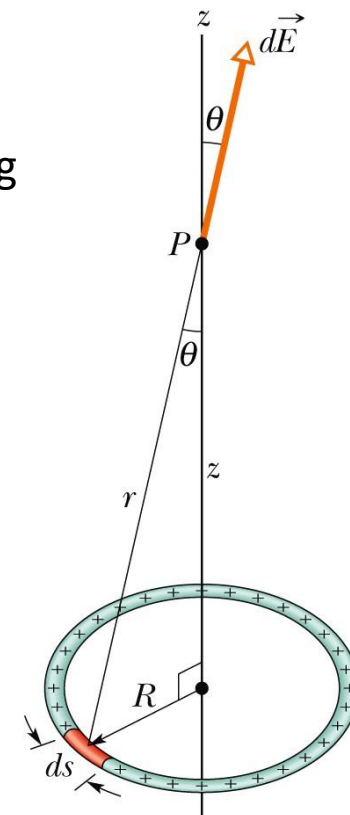

Copyright © 2014 John Wiley & Sons, Inc. All rights reserved.

A ring of uniform positive charge. A differential element of charge occupies a length ds (greatly exaggerated for clarity). This element sets up an electric field $d\vec{E}$ at point P .

22-4 The Electric Field Due to a Line of Charge

Charged Ring

Integrating. Because we must sum a huge number of these components, each small, we set up an integral that moves along the ring, from element to element, from a starting point (call it $s=0$) through the full circumference ($s=2\pi R$). Only the quantity s varies as we go through the elements. We find

$$E = \int dE \cos \theta = \frac{z\lambda}{4\pi\epsilon_0(z^2 + R^2)^{3/2}} \int_0^{2\pi R} ds$$

Finally,

$$E = \frac{qz}{4\pi\epsilon_0(z^2 + R^2)^{3/2}} \quad (\text{charged ring}).$$

The components perpendicular to the z axis cancel; the parallel components add.

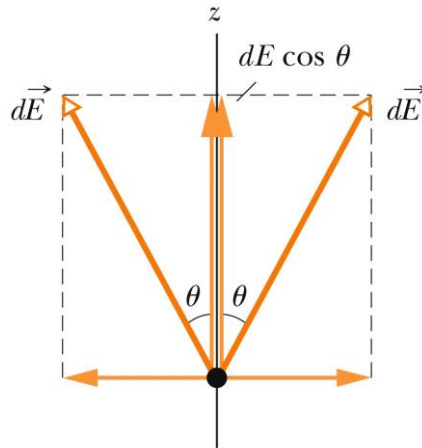

Copyright © 2014 John Wiley & Sons, Inc. All rights reserved.

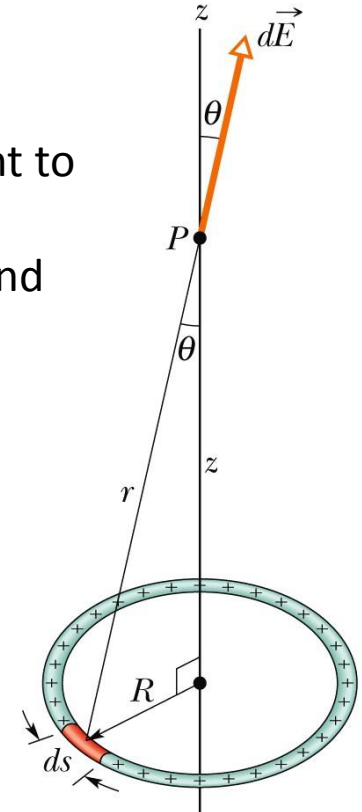

Copyright © 2014 John Wiley & Sons, Inc. All rights reserved.

A ring of uniform positive charge. A differential element of charge occupies a length ds (greatly exaggerated for clarity). This element sets up an electric field dE at point P .

22-5

The Electric Field Due to a Charged Disk

22-5 The Electric Field Due to a Charged Disk

Learning Objectives

- **22.19** Sketch a disk with uniform charge and indicate the direction of the electric field at a point on the central axis if the charge is positive and if it is negative.
- **22.20** Explain how the equation for the electric field on the central axis of a uniformly charged ring can be used to find the equation for the electric field on the central axis of a uniformly charged disk.
- **22.21** For a point on the central axis of a uniformly charged disk, apply the relationship between the surface charge density σ , the disk radius R , and the distance z to that point.

22-5 The Electric Field Due to a Charged Disk

We superimpose a ring on the disk as shown in the Figure, at an arbitrary radius $r \leq R$. The ring is so thin that we can treat the charge on it as a charge element dq . To find its small contribution dE to the electric field at point P, on the axis, in terms of the ring's charge dq and radius r we can write

$$dE = \frac{dq z}{4\pi\epsilon_0(z^2 + r^2)^{3/2}}$$

Then, we can sum all the dE contributions with

$$E = \int dE = \frac{\sigma z}{4\epsilon_0} \int_0^R (z^2 + r^2)^{-3/2} (2r) dr,$$

We find

$$E = \frac{\sigma}{2\epsilon_0} \left(1 - \frac{z}{\sqrt{z^2 + R^2}} \right) \quad (\text{charged disk})$$

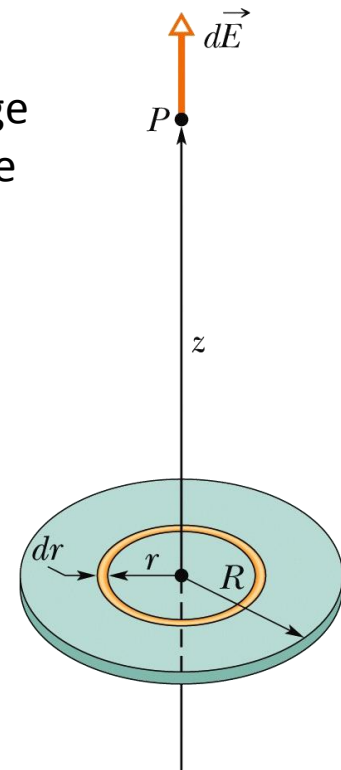

Copyright © 2014 John Wiley & Sons, Inc. All rights reserved.

A disk of radius R and uniform positive charge. The ring shown has radius r and radial width dr . It sets up a differential electric field dE at point P on its central axis.

22-6

A Point Charge in an Electric Field

22-6 A Point Charge in an Electric Field

Learning Objectives

- **22.22** For a charged particle placed in an external electric field (a field due to other charged objects), apply the relationship between the electric field \mathbf{E} at that point, the particle's charge q , and the electrostatic force \mathbf{F} that acts on the particle, and identify the relative directions of the force and the field when the particle is positively charged and negatively charged.
- **22.23** Explain Millikan's procedure of measuring the elementary charge.
- **22.24** Explain the general mechanism of ink-jet printing.

22-6 A Point Charge in an Electric Field

If a particle with charge q is placed in an external electric field \vec{E} , an electrostatic force \vec{F} acts on the particle:

$$\vec{F} = q\vec{E}.$$



The electrostatic force \vec{F} acting on a charged particle located in an external electric field \vec{E} has the direction of \vec{E} if the charge q of the particle is positive and has the opposite direction if q is negative.

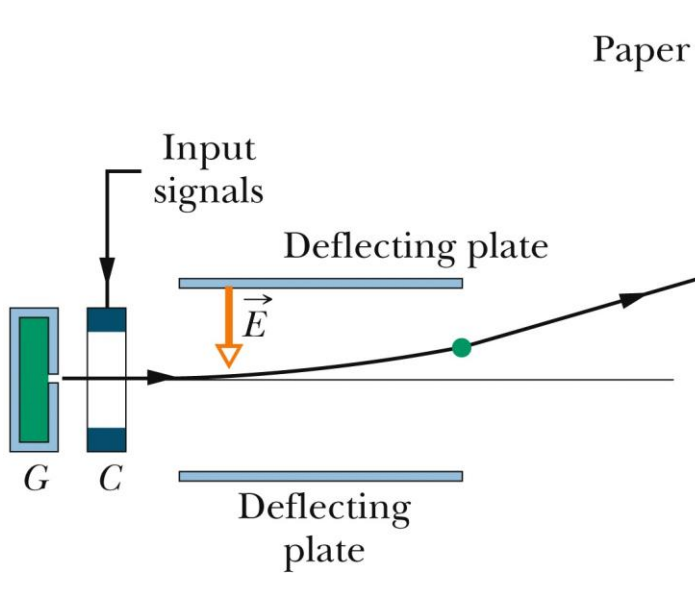

Ink-jet printer. Drops shot from generator G receive a charge in charging unit C . An input signal from a computer controls the charge and thus the effect of field \vec{E} on where the drop lands on the paper.

22-6

A Dipole in an Electric Field

22-7 A Dipole in an Electric Field

Learning Objectives

- **22.25** On a sketch of an electric dipole in an external electric field, indicate the direction of the field, the direction of the dipole moment, the direction of the electrostatic forces on the two ends of the dipole, and the direction in which those forces tend to rotate the dipole, and identify the value of the net force on the dipole.
- **22.26** Calculate the torque on an electric dipole in an external electric field by evaluating a cross product of the dipole moment vector and the electric field vector, in magnitude-angle notation and unit-vector notation.
- **22.27** For an electric dipole in an external electric field, relate the potential energy of the dipole to the work done by a torque as the dipole rotates in the electric field.

22-7 A Dipole in an Electric Field

Learning Objectives

- **22.28** For an electric dipole in an external electric field, calculate the potential energy by taking a dot product of the dipole moment vector and the electric field vector, in magnitude-angle notation and unit-vector notation.
- **22.29** For an electric dipole in an external electric field, identify the angles for the minimum and maximum potential energies and the angles for the minimum and maximum torque magnitudes.

22-7 A Dipole in an Electric Field

The torque on an electric dipole of dipole moment \vec{p} when placed in an external electric field \vec{E} is given by a cross product:

$$\vec{\tau} = \vec{p} \times \vec{E} \quad (\text{torque on a dipole}).$$

A potential energy U is associated with the orientation of the dipole moment in the field, as given by a dot product:

$$U = -\vec{p} \cdot \vec{E} \quad (\text{potential energy of a dipole}).$$

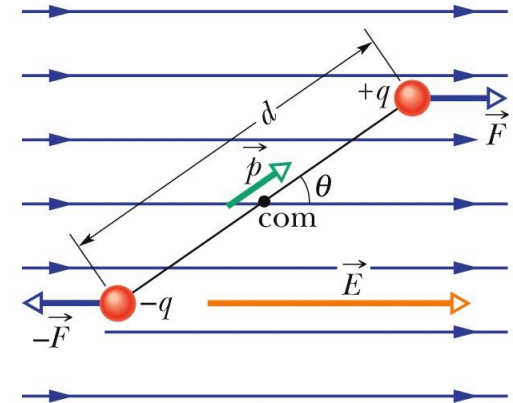

(a)

The dipole is being torqued into alignment.



(b)

Copyright © 2014 John Wiley & Sons, Inc. All rights reserved.

- An electric dipole in a uniform external electric field \vec{E} . Two centers of equal but opposite charge are separated by distance d . The line between them represents their rigid connection.
- Field \vec{E} : causes a torque $\vec{\tau}$ on the dipole. The direction of $\vec{\tau}$ is into the page, as represented by the symbol (x-in a circle).

22 Summary

Definition of Electric Field

- The electric field at any point

$$\vec{E} = \frac{\vec{F}}{q_0} \quad \text{Eq. 22-1}$$

Electric Field Lines

- provide a means for visualizing the directions and the magnitudes of electric fields

Field due to a Point Charge

- The magnitude of the electric field E set up by a point charge q at a distance r from the charge is

$$E = \frac{1}{4\pi\epsilon_0} \frac{|q|}{r^2} \quad \text{Eq. 22-3}$$

Field due to an Electric Dipole

- The magnitude of the electric field set up by the dipole at a distant point on the dipole axis is

$$E = \frac{1}{2\pi\epsilon_0} \frac{p}{z^3} \quad \text{Eq. 22-9}$$

Field due to a Charged Disk

- The electric field magnitude at a point on the central axis through a uniformly charged disk is given by

$$E = \frac{\sigma}{2\epsilon_0} \left(1 - \frac{z}{\sqrt{z^2 + R^2}} \right) \quad \text{Eq. 22-26}$$

Force on a Point Charge in an Electric Field

- When a point charge q is placed in an external electric field \vec{E}

$$\vec{F} = q\vec{E}. \quad \text{Eq. 22-28}$$

Dipole in an Electric Field

- The electric field exerts a torque on a dipole

$$\vec{\tau} = \vec{p} \times \vec{E}. \quad \text{Eq. 22-34}$$

- The dipole has a potential energy U associated with its orientation in the field

$$U = -\vec{p} \cdot \vec{E}. \quad \text{Eq. 22-38}$$